

DRYPOINT® AC

Adsorption dryers
with exceptionally
low operating costs

135 - 1.550
m³/h



SAVING OF ENERGY COSTS PAYS THE COST PRICE

THIS IS THE FACT

The operation of compressed air systems with conventional adsorption dryers suffers from system-related pressure drop. This deficiency needs to be compensated via an increased compressor performance, this requiring a higher energy demand.

Cold-regenerated DRYPOINT® AC adsorption dryers offer a convincing solution to the problem: BEKO has developed an adsorption dryer which limits the pressure drop to an average of only 0.25 bar, including the pre- and final filters. Compared with conventional constructions, this represents an improvement of over 50%. Thus, acquisition costs will be repaid through energy savings costs after an average of only three years.

We would also be happy to inform you about our DRYPOINT® AC program for volume flows of 10-112 m³/h. For this purpose, please ask for the respective brochure.



+1:

+2:

+3:

+4:

+5:

The pressure drop of a dryer exerts a decisive influence on the energy costs which constitute up to 80% of the total operating costs. For a dryer, designed for a compressor performance of 110 Kw (4000 operating hours, 8 ct/Kwh), cost savings of up to € 1000 per annum may be achieved in such a way.

Energy costs in Euro per annum

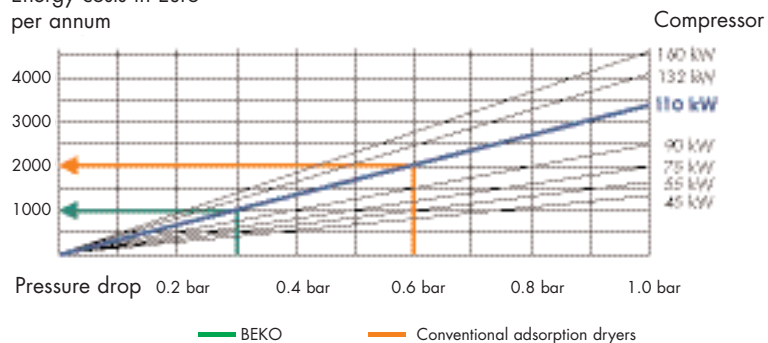



SPECIFIC ADVANTAGES

DRYPOINT® AC adsorption dryers are equipped with CLEARPOINT® compressed air filters and BEKOMAT® condensate drains. That is best compressed air processing as a complete solution from the BEKO company.

COST SAVING POTENTIALS / BENEFITS

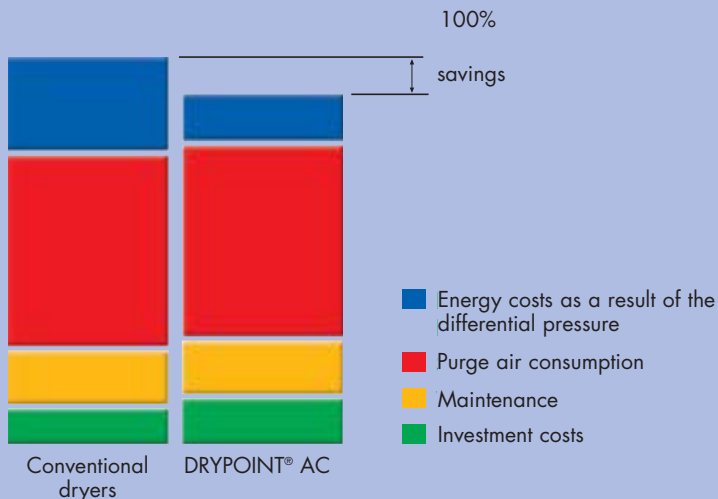

REDUCTION OF OPERATING COSTS

HIGH OPERATIONAL SAFETY

EASY TO MAINTAIN

EASY TO INSTALL

CUSTOM-MADE CONCEPT

IN THE FOLLOWING FIELDS, ADSORPTION DRYERS HAVE BEEN SUCCESSFULLY APPLIED

- Breathable air, medical air
- Chip production, blow air/instrument air
- Bottling plants
- Photo industry/film processing
- Glass manufacture, process air/cooling air
- High-rise warehouse/grab systems
- Climatic exposure test cabinets
- Plastic drying/plastic dryers
- Painting plants
- Food industry, bottling/bagging of hygroscopic food
- Measuring containers
- Optical measuring machines
- Pneumatic control systems
- Testing of electronic circuit printed boards
- Sprinkler systems
- Transport of bulk goods, e.g. coal dust
- Packaging machines



THEREFORE, DRYPOINT® AC IS THE BEST CHOICE

LOW ENERGY COSTS AS A RESULT OF A PRESSURE DROP LOWER BY 50%

Components

- All components of the DRYPOINT® AC are adjusted to each other with regard to flow optimization (e.g. arched flow direction in the CLEARPOINT® compressed air filters, large pipe cross sections, large-scale valve cross sections).
- Large drying agent bed: This offers additional capacity for the maintenance of the full drying performance, e.g. at an unexpectedly high volume flow or low operating pressure.
- A minimum of two silencers, installed parallel to each other, reduce the sound.
- Due to the particularly large surface area of the silencers, a long serviceable life and reduced dynamic pressure is achieved. The flow rate is reduced and, therefore, an extremely low pressure drop builds up. This will save considerable quantities of regeneration air.
- An adjustable regeneration air nozzle enables the changeover to other operating conditions and offers additional operational reliability with regard to the dosage of the correct quantity of regeneration air.

Control

- DRYPOINT® AC is also suitable for discontinuous operation. Reduction of the regeneration air corresponds to the actual requirements via coupling with the compressor (compressor synchronisation control). An optional, load-dependent control may be retrofitted at any time.



Adjustable regeneration air nozzle



Optional: pressure dew point monitoring and load-dependent control

HIGH OPERATIONAL SAFETY USING A CONVINCING CONCEPT

Fail-safe

- At an external interruption of the power supply, conventional dryers are overloaded and lose their ability to function. The consequence: water is introduced into the compressed air system. The concept of the DRYPOINT® AC prevents unwanted loading of the dryer during interruption of the power supply and guarantees preservation of the function. The compressed air system remains dry.

Reliable components

- Exclusively standardized valves of well-known manufacturers are used. Spare parts may be procured worldwide, promptly and without problems.
- Both drying agent containers are kept under alternating pressure. Therefore, they are designed to be durable throughout alternating pressure operation, and functional with all fittings. Their suitability for unlimited load alterations prolongs their lifespan and eliminates any risk for personnel as well as for the system.

Efficient drying agent

- The special BEKO drying agent offers a large, active surface for the absorption of humidity.
- The dimensionally stable, water-resistant drying agent free from wear allows the densest possible filling.
- There are no function-obstructing bypasses.



EXTREMELY EASY TO MAINTAIN

- All components are accessible from the front. No time-consuming dismounting and remounting of the pipe bridge is required for replacement of the drying agent.
- Each container is equipped with an overhead, easily accessible service sleeve.

EASY INSTALLATION

- DRYPOINT® AC is particularly convenient for tight spaces. Transport has also been taken into account: The supporting frame is suitable for load platforms.
- The dryer will be assembled and serviceable, when delivered (up to 800 m³).

YOUR CUSTOM-MADE DRYPOINT® AC

- Factory adjustment to the operating pressure.
- For an optimum integration of the dryer into the existing compressed air system, BEKO offers a variety of options. Amongst other things, these are: a load-dependent control, automatic starting control and an extensive filter program (e.g. CLEARPOINT® activated carbon filters, sterile filters, nanofilters).

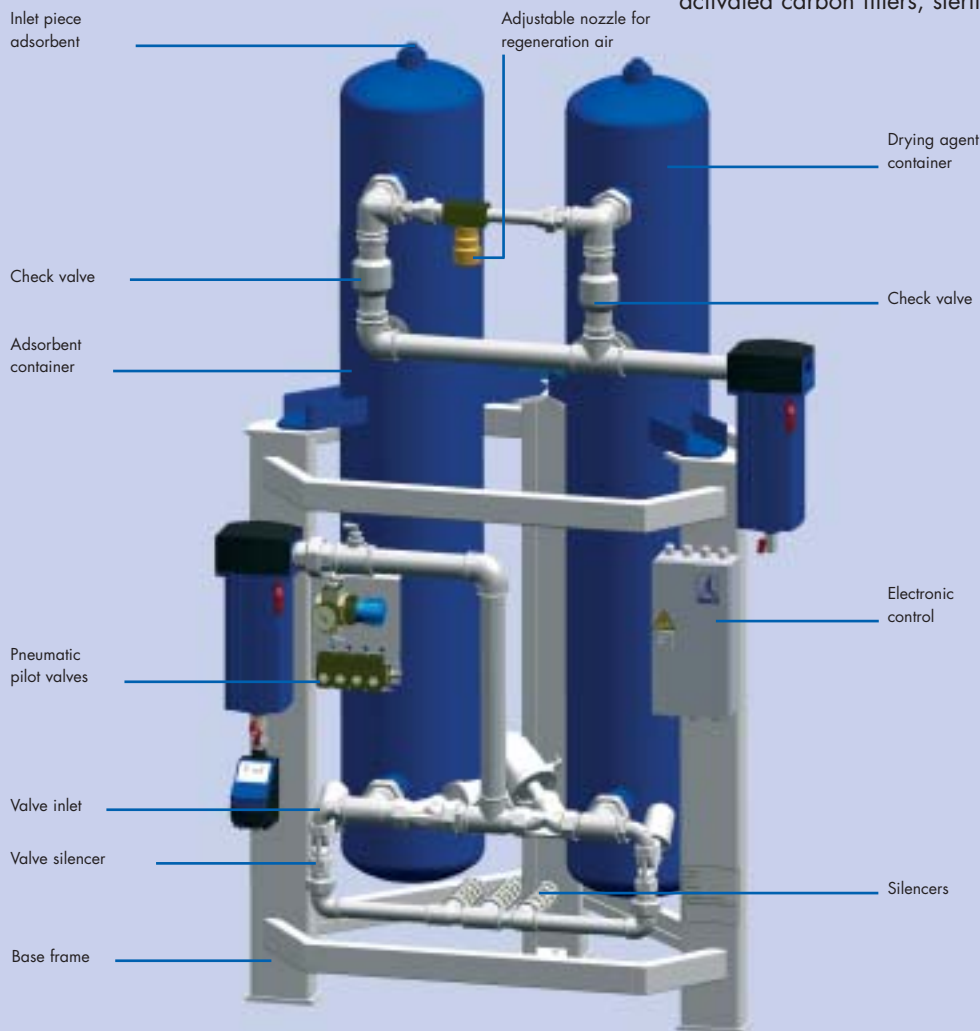

DRYPOINT® AC

TECHNICAL INFORMATION AND DATA

CONTROL

Standard:

Compressor synchronisation control

In connection with a compressor, the control reduces the energy demand of the dryer to the required minimum. When the compressor works, the dryer will be energized correspondingly. The shortened load period saves energy costs and reduces wear and tear. The integrated continuous memory of the DRYPOINT® AC's control thus ensures safe and overload-free operation.

Optional:

retrofitable, load-dependent control

A load-dependent control uses the saving potentials of a dryer particularly efficiently and reduces the operating costs. As far as conventional dryers are concerned, retrofitting requires the complete and costly replacement of the control. As regards the DRYPOINT® AC, the load-dependent control is an optional extension which does not require the complete replacement of the control. Due to enormous energy savings at almost negligible installation costs, such an investment often pays off after an operating period of 6 months.

THE COMPLETE DRYPOINT® PROGRAM

Air quality according to ISO8573-1 Pressure dew point

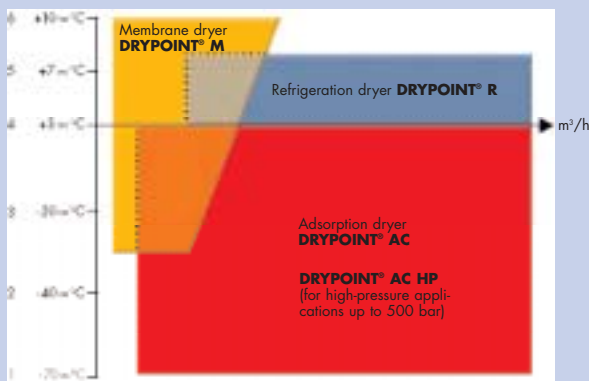

Broadband power supply

Internationally usable, works with almost every supply voltage: 100 – 240 VAC, 50 – 60 Hz and 24 VDC. Other voltages optional.

Protection class IP54

Extra-protection against splashes of water.

	Connection	Volume flow		Dimensions					Weight kg
		m³/h	scfm	A	B	C	D	E	
AC 205	G 1	135	79.5	1610	780	530	1430	755	190
AC 210	G 1	155	91.2	1800	780	530	1620	755	255
AC 215	G 1	200	117.7	1500	780	530	1310	755	280
AC 220	G 1½	280	164.8	1520	980	635	1310	910	360
AC 225	G 1½	380	223.7	1820	980	635	1590	910	440
AC 230	G 1½	500	294.3	1800	980	635	1590	910	550
AC 240	G 2	630	370.8	1840	980	635	1580	1000	640
AC 250	G 2	800	470.9	1860	1360	940	1565	1000	820
AC 260	G 2½	1000	588.6	1840	1360	940	1515	1140	950
AC 275	G 2½	1250	735.7	1830	1360	940	1525	1140	1100
AC 295	G 2½	1550	912.3	1900	1360	940	1555	1140	1230

As far as adsorption dryers <135 m³/h are concerned, you will find information in a separate brochure.

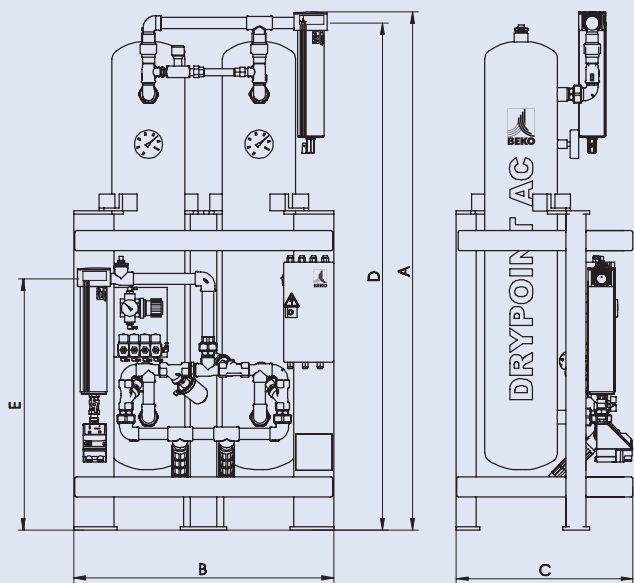

TECHNICAL DATA

Maximum operating overpressure	Type AC 205 – AC 250: 16 bar Type AC 260 – AC 295: 10 bar (16 bar optional) Higher nominal output on request.
Pressure dew point default setting (outlet)	-40 °C
Optional pressure dew points	-20 °C / -70 °C min./max.
Inlet temperature air	2 °C / 50 °C min./max.
Ambient temperature	5 °C / 50 °C min./max.
Electric power supply (other voltages on request)	24 VDC
Input filter	0,01 µm
Output filter	1,0 µm

THE FUNCTIONAL PRINCIPLE

DRYPOINT® AC are cold-regenerated adsorption dryers which function using the alternating pressure method.

Two containers, filled with strongly hygroscopic drying agents, are placed in parallel with each other. While compressed air is dried in one of these containers, regeneration of the drying agent takes place in the other. In a defined rhythm, a time dependent control switches over from one container to the other.

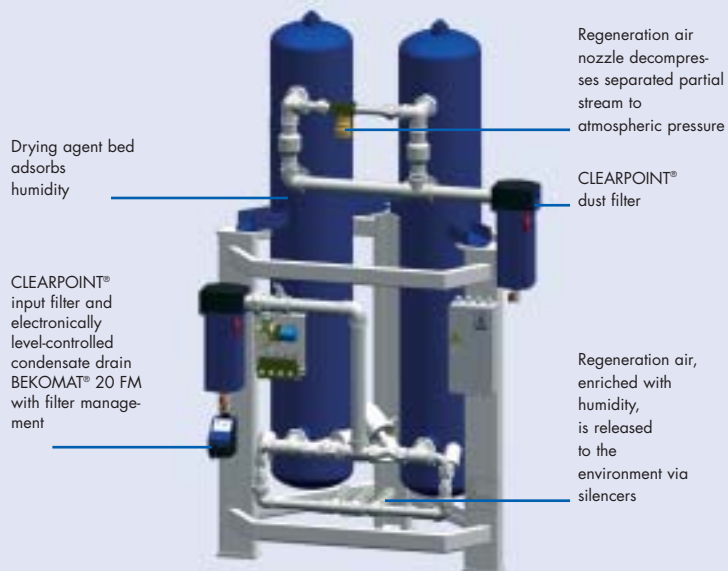

Performance data according to DIN ISO 7185 relate to an input pressure of 7 bar (overpressure) and an inlet temperature of 35°C. Please multiply with the corrective factors where the input conditions deviate.

Corrective factors pressure / temperature

bar	4	5	6	7	8	9	10	11	12	13	14	15	16
35 °C	0.63	0.75	0.88	1.00	1.13	1.25	1.38	1.50	1.63	1.75	1.88	2	2.12
40 °C	0.55	0.66	0.77	0.88	0.99	1.10	1.21	1.32	1.43	1.54	1.65	1.76	1.87
45 °C	0.42	0.50	0.59	0.67	0.76	0.84	0.92	1.01	1.09	1.17	1.26	1.34	1.42
50 °C	0.35	0.41	0.48	0.55	0.62	0.69	0.76	0.83	0.90	0.96	1.03	1.10	1.17

Regeneration air in %

DTP -20 °C outlet	18.0	15.4	12.9	11.3	10.0	9.1	8.2	7.6	7.0	6.5	6.0	5.6	5.3
DTP -40 °C outlet	24.0	20.5	17.1	14.8	13.3	12.1	10.9	10.0	9.2	8.6	8.0	7.4	7.1
DTP -70 °C outlet	26.7	22.8	19.0	16.7	14.8	13.4	12.1	11.2	10.3	9.6	8.9	8.4	7.9



BEKO

HIGH-QUALITY COMPRESSED-AIR SUPPLY

BEKOMAT®

The convincing concept for condensate drainage

ÖWAMAT®

Clean and safe oil-water separation. Enhanced efficiency with OEKOSORB® replacement filters

BEKOSPLIT®

Splitting plants for the reliable, economic and environmentally friendly treatment of emulsions

DRYPOINT®

The complete spectrum of products for compressed-air drying: refrigeration dryers, adsorption dryers, membrane dryers

CLEARPOINT®

Highly reliable, flow-optimised filters and water separators for compressed air and industrial gases

BEKOFLOW®

The innovative, cost-cutting compressed-air pipe system

BEKOBLIZZ®

Optimised cooling processes using deep-cooled, dry compressed air.

® Registered trademarks of BEKO TECHNOLOGIES GmbH, Neuss, Germany



BEKO TECHNOLOGIES GMBH

Im Taubental 7 Telefon +49 2131 988-0
41468 Neuss Telefax +49 2131 988-900
www.beko.de beko@beko.de



Subject to technical changes without prior notice; the information provided does not represent characteristics of state within the meaning of the German Civil Code (BGB).